

VKMA 01031

VKMC 01031

VKMA 01032

VKMC 01032



A



- (4): Locking key (ref. VAG 2084).
- (6): Extractor (ref. VAG 3034).
- (-): Locking key (ref. VAG 3036).

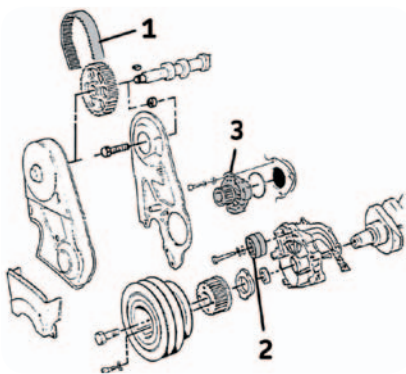

- (2) = 10 Nm
- (5) = 20 Nm

B

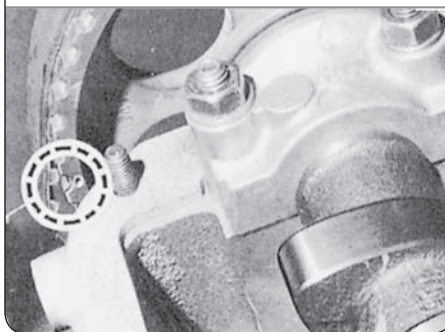

C

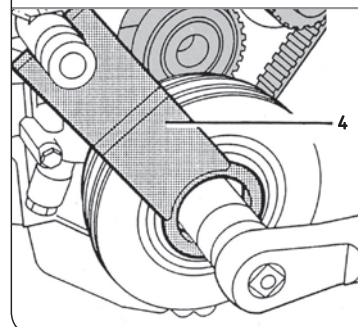

Removal

- 1) Disconnect the battery according to the vehicle manufacturing guidelines.
- 2) Prepare the vehicle for the timing replacement according to the vehicle manufacturing guidelines.
- 3) Set cylinder Nr 1 at Top Dead Centre (TDC). Check the alignment of the mark on the camshaft sprocket with the cylinder head sealing surface (Fig. B) and mark on the flywheel with that on the clutch housing.
- 4) Engage 5th gear, loosen and remove the 4 bolts securing the pulley on the crank gear.
- 5) Lock the crank pulley with tool (4) (Fig. C).
- 6) Loosen and remove the bolt at the centre of the crank pulley.
- 7) Remove tool (4) then remove the crank pulley (Fig. C).
- 8) Loosen the fastening bolts (5) of the water pump (3) and tilt it clockwise to loosen the belt (Fig. D).
- 9) Remove the timing belt (1) (Fig. A).
- 10) According to the fitting: remove the idler roller (2) using the extractor (6) (Fig. E).
- 11) **Removing the water pump (VKMC 01031/ VKMA 01032):** Firstly bleed the cooling circuit, check it is clean, and clean if required; secondly fully loosen the water pump (3) fastening bolts and remove the pump (Fig. A).

Install Confidence

Refitting

Caution! Clean the bearing surfaces of the rollers.

- 12) **Refitting the water pump:** Firstly fit the new water pump (3), and tighten the waterpump with TORQUE to manufacturer recommendations then check that the water pump pulley runs properly, and has no hard or locking spots.
- 13) According to the fitting: reassemble the new idler roller (2) to a torque of **10 Nm (Fig. A)**.
- 14) Fit the new timing belt (1) (Fig. A).
- 15) Tilt the water pump (3) **counter-clockwise** to tighten the timing belt (Fig. D).
- 16) Tighten the water pump fastening bolts (5) at **20 Nm**.
- 17) Check the tension of the timing belt (1) **according to manufacturer recommendations**.
- 18) Engage the 5th gear, reassemble the crank pulley (centred on the crank pinion) by aligning its marker with that on the oil pump casing (Fig. G) then tighten the 4 fastening bolts at **20 Nm**.
- 19) Lock the crank pulley with tool (4) (Fig. C).
- 20) Fit the central crank pulley bolt smeared with Loctite locking compound, and tighten at **100 Nm + 180°**.
- 21) Remove tool (4) (Fig. C).
- 22) Turn the crankshaft by two turns and check the alignment of the TDC shimming marks.
- 23) Refit the removed elements in reverse order to removal
- 24) Fill the cooling circuit with the permanent fluid recommended.
- 25) Check the circuit's leak-tightness when the engine reaches its running temperature and secure the level of coolant when the engine is at ambient temperature (20 °C)

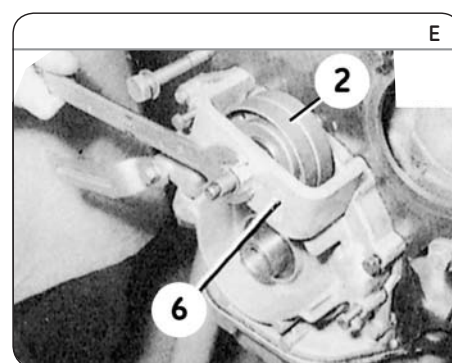
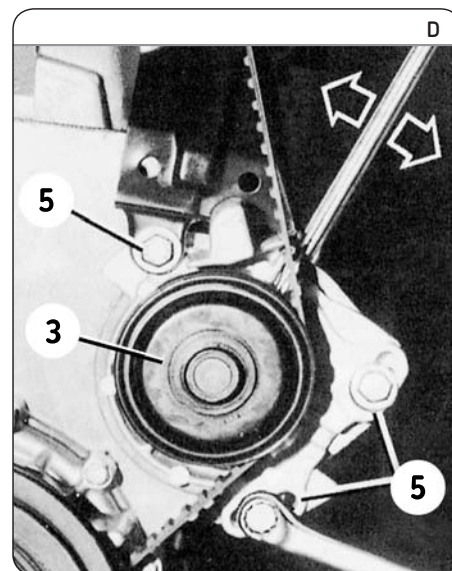

Notice: Always follow the vehicle manufacturer instructions when working on the engine. The SKF KITS are designed for the automotive repair professional and must be fitted using tooling used by these professionals. These instructions are to be used as a guideline only. This document is the exclusive property of SKF. Any representation, partial or full reproduction, is forbidden without prior written consent from SKF.

© SKF is a registered trademark of the SKF Group.

© SKF Group 2014

The contents of this publication are the copyright of the publisher and may not be reproduced (even extracts) unless prior written permission is granted. Every care has been taken to ensure the accuracy of the information contained in this publication but no liability can be accepted for any loss or damage whether direct, indirect or consequential arising out of the use of the information contained herein. Any cost savings and revenue increases in this publication are based on results experienced by SKF customers and do not constitute a guarantee that any future results will be the same.

PUB 80/11 15081 EN · November 2014

